

Digi m10™

Compact Satellite Modem

Small footprint satellite modem with global satellite connectivity is designed for a wide variety of asset tracking and remote device communication applications.



Overview

The Digi m10 satellite module provides worldwide satellite data connectivity for a wide variety of asset-tracking and industrial remote communication applications.

Operating on the ORBCOMM low-earth orbit (LEO) satellite network, it is designed to enable cost-efficient Machine-to-Machine (M2M) communication with virtually unlimited global coverage and no blockage. All at a typical low monthly cost comparable to cellular plans for low data volume M2M applications.

Built on Digi's own patented mixed signal chip designed and tailored for satellite applications, the Digi m10 modem offers immediate product design integration through its integrated serial interface. With full support for industrial temperature and operational shock/vibration specifications exceeding SAE J1455, it is the ideal choice for reliable and highly cost-efficient satellite connectivity in even the most demanding application.

The Digi m10 kits provide all necessary components for quick and easy product evaluation, development and prototyping.

Target Applications



Utilities



Industrial Automation



Remote Device Management



Transportation



Security

Application Highlight

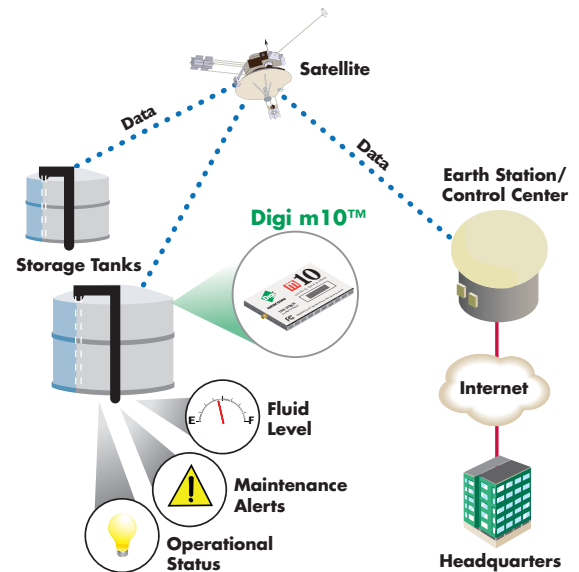

Features/Benefits

- Cost-efficient with leading performance
- Global LEO satellite coverage (no blockage)
- Extremely compact module form factor
- Highly integrated using Digi satellite technology
- Very low transmit and receive power
- Industrial operating temperature
- Highly shock and vibration resistant
- Quick and simple product design integration
- Direct PCB mount or cable connection



Specifications

Digi m10™

Application Interface	
Header	14-pin socket, 1 mm pitch (Samtec P/N MLE-107-01-G-DV-K)
Serial Port	UART (3.3V TTL), 2-wire, with modem power on/off control option through DTR signal
Wake Trigger	Satellite Available (SA), Data Available (DA)
Satellite Communications	
Antenna Connector	MMCX male connector (50 Ω)
Minimum Detectable Signal	-120 dBm (typical)
Transmit Power	5W nominal
Frequencies	TX: 148-150.05 MHz RX: 137-138 MHz
Power Requirements	
Input Voltage	+9 to 18VDC
Transmit Current	1.5A max @ +12VDC
Receive Current	60 mA max @ +12VDC
Mechanical	
Dimensions (L x W x H)	2.95 in x 1.81 in x 0.52 in (7.49 cm x 4.60 cm x 1.32 cm)
Environmental	
Operating Temperature	-40° C to +85° C (-40° F to +185° F)
Relative Humidity	0% to 95% (non-condensing)
Shock (Operational)	Exceeds SAE J1455 levels
Vibration (Operational)	Exceeds SAE J1455 levels
Radiated Emissions	EN300 832, EN301-721
Regulatory Approvals	US (FCC), EU (CE), Australia/New Zealand (C-Tick), Canada (IC) - pending, Japan (Telec) - pending

Digi m10 Host Interface

Pin	Signal	Description	
1	VCC	Supply	9-18V DC
2	GND	Ground	
3	VCC	Supply	9-18V DC
4	GND	Ground	
5	PWR_EN (DTR)	Power Enable	Pulled low (47kΩ)
6	GND	Ground	
7	RXD	Receive Data	Host UART interface
8	TXD	Transmit Data	Host UART interface
9	SA	Satellite Available	
10	DA	Data Available	
11	DBG TXD	Transmit Data	Debug UART interface
12	DBG RXD	Receive Data	Debug UART interface
13	Reserved	Reserved	
14	Reserved	Reserved	

Digi m10 Mechanical Drawing

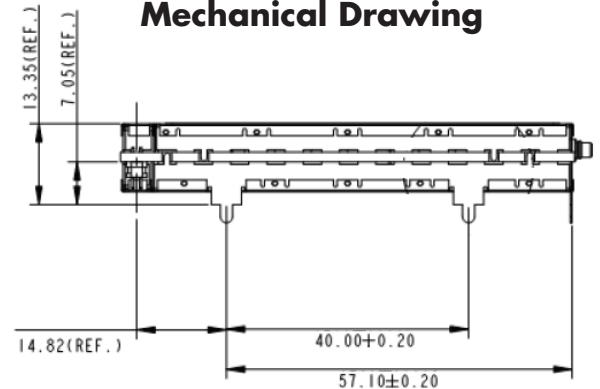

Visit www.digi.com for part numbers.

DIGI SERVICE AND SUPPORT - You can purchase with confidence knowing that Digi is here to support you with expert technical support and a strong one-year warranty. www.digi.com/support

Digi International
877-912-3444
952-912-3444
info@digi.com

Digi International France
+33-1-55-61-98-98
www.digi.fr

Digi International KK
+81-3-5428-0261
www.digi-intl.co.jp

Digi International (HK) Limited
+852-2833-1008
www.digi.cn



91001549
A4/1209

BUY ONLINE • www.digi.com

© 2009 Digi International Inc.
Digi, Digi International, the Digi logo, the Making Wireless M2M Easy logo and Digi m10 are trademarks or registered trademarks of Digi International Inc. in the United States and other countries worldwide. All other trademarks are the property of their respective owners.

