



GS2100M Low Power, High Speed 802.11b/g/n module

Smart Energy, Cost Optimized



The GS2100M module provides a quick, easy, and cost effective way for device and appliance manufacturers to add Wi-Fi connectivity to their products. Intended for smart energy and sensor applications, the module runs the SEP 2.0 Smart Energy Profile stack and has 3 high bit-rate sigma-delta ADCs for high resolution sensor and measurement devices.

This module provides a low cost, high speed serial to Wi-Fi connection to an embedded design built on an 8/16/32-bit microcontroller, achieving up to 40 Mbps throughput over an SDIO interface.

The GS2100M is an ideal solution for organizations with limited Wi-Fi or RF expertise or for those seeking faster time to market, as it reduces RF design time and removes the burden of testing and certification. The module is IEEE 802.11b/g/n compliant, and meets worldwide regulatory and Wi-Fi Alliance certification requirements.

The module runs the full Wi-Fi and TCP/IP networking stacks, completely offloading the host microcontroller. It supports a complete suite of security protocols, also without tasking the host microcontroller, including WPA/WPA2-Enterprise and Personal security modes, legacy WEP encryption, and upper layer security protocols such as TLS/SS and HTTPs. Alternatively, it can be run self-contained without a host.

For ease of provisioning, the module can be set up simply and easily from a smartphone or laptop through the innovative Limited AP mode or with Wi-Fi Protected Setup (WPS).

The module is single sided with castellation on the edges for the I/O connections for soldering down on the product's baseboard.

The GS2100M has extended range with industry leading receiver sensitivity. It is available with a u.FL connector to add an external antenna for max performance or a PCB antenna for convenience while saving space. It is US/Canada (FCC /IC), Europe (ETSI) and Japan (TELEC) certified.

SKU	Antenna Option
GS2100MIE	External Antenna
GS2100MIP	PCB Antenna

BENEFITS:

- Enables SEP 2.0 Smart Energy Profiles
- High resolution sensing and energy measurement
- Adds low power, high speed Wi-Fi and Internet connectivity to any device with a microcontroller and serial host interface
- Certified module reduces development time, testing and certification, accelerating time to market
- Full offload solution minimizes load on host processor
- Easy smartphone provisioning with Limited AP or Wi-Fi Protected Set-up (WPS)
- Ultra low power consumption through dynamic power management modes
 - Standby, Sleep, Deep Sleep
- Extended range

FEATURES:

- SEP 2.0 Smart Energy Device Types:
 - Smart Thermostat
 - Load Control
- 3 16-bit Sigma-Delta ADCs for sensors and measurement
- IEEE 802.11 b/g/n connectivity with PHY rates up to 72 Mbps
- Limited AP, Wi-Fi Direct with concurrent mode, WPS 2.0
- UART, SPI, SDIO interface to microcontroller
- Throughput (typical): 40 Mbps on SDIO, 30 Mbps on SPI (master), 12 Mbps on SPI (slave) , and 1 Mbps on UART
- Extensive networking stack and services
- Security: 802.11i, WPA/2–Personal and Enterprise, legacy WEP, TLS



GS2100M MODULE SPECIFICATIONS

Radio Protocol	IEEE 802.11b/g/n
Pin Count	40 pins
RF Output Power (Typical)	+15 dBm (802.11b), +11 dBm (802.11n)
Rx Sensitivity	-95 dBm
Wake From Standby Time	1 ms (1 millisecond)
RF Operating Frequency	2.4 - 2.495 GHz
Supported Data Rates	72, 65, 58, 43, 29, 22, 14, 7 Mbps (802.11n), 54, 48, 36, 24, 18, 12, 9, 6 Mbps (802.11g) 11, 5.5, 2, 1 Mbps (802.11b)
Antenna Options	External antenna (u.FL connector) or Internal PCB trace antenna
Operating Temperature	-40° to +85°C
Security Protocols	WPA/WPA2 - Personal, WPA/WPA2 - Enterprise (PEAP, EAP-FAST, EAP-TLS, EAP-TTLS), WEP, TLS/SSL Client and Server, HTTPs
Networking Protocols	TCP, UDP, IPv4, IPv6, TLS Client and Server, SNTP client, DHCP Client and Server v4, DHCP Client and Server v6, DNS Client and Server, mDNS, DNS-SD, HTTP Client and Server, and XML Parser
Certifications and Compliance	FCC, IC, TELEC, ETSI, RoHS, Wi-Fi CERTIFIED, Wi-Fi Direct, WPS 2.0, SEP 2.0
I/O Interfaces	SPI, UART, SDIO, I ² C, GPIO, ADC (16 bit), ADC (12 bit), JTAG
Host Connections	SPI, UART, SDIO (typically to an external microcontroller)
Internal Flash	2 MB
Outline Dimensions	18 mm x 25 mm x 2.5 mm (shield)
I/O Voltage	2.7-3.6V
Operating Voltage	2.7-3.6V
V_{BAT}	1.6-3.6V

TARGET APPLICATIONS

The GainSpan GS2100M module is easily designed into embedded systems, allowing customers to develop a broad array of devices and appliances that connect to other local devices or the Internet over Wi-Fi. Applications include smart energy, healthcare and fitness, industrial controls, commercial building automation, and consumer electronics.

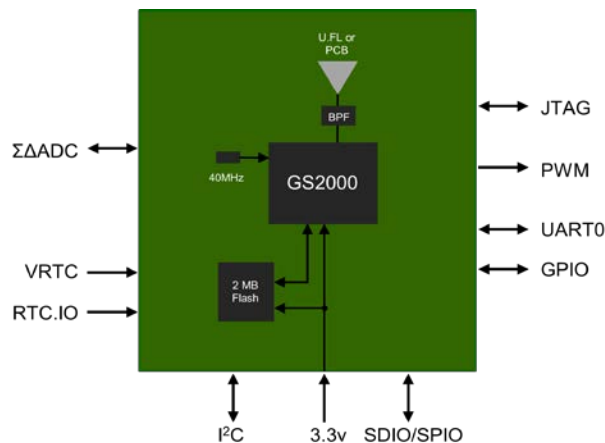

GS2100 Block Diagram

