

## SQ-SEN-200 APPLICATION CIRCUITS

### FLEXIBLE FILTER CIRCUIT

- Best choice for a simple, flexible interface circuit. Provides opportunity for filtering if needed. For most applications, this is the recommended circuit.
- For low power applications a good starting value for R1 is 4.7M. R2 can be 100K – 1M to depending on the desired output swing.
- Using R1 of 4.7M and R2 of 1M, the current consumption will be about 0.5  $\mu$ A (0.0005 mA) for a Vcc of 3.0 V.
- Higher values for R1 and R2 can be used to further limit the current, but board impedances must be considered if higher resistance is used.
- Experiment with C1 values for various filtering options. Generally 10 – 100 pF is sufficient for general signal edge clean up. A larger C1 value i.e. 1000 pF will turn the digital output into an analog average value. A low leakage capacitor should be used.
- **Note:** It is recommended to use a 10x probe for circuit debugging. If a 1x probe is used, the series resistance will cause a large voltage droop.

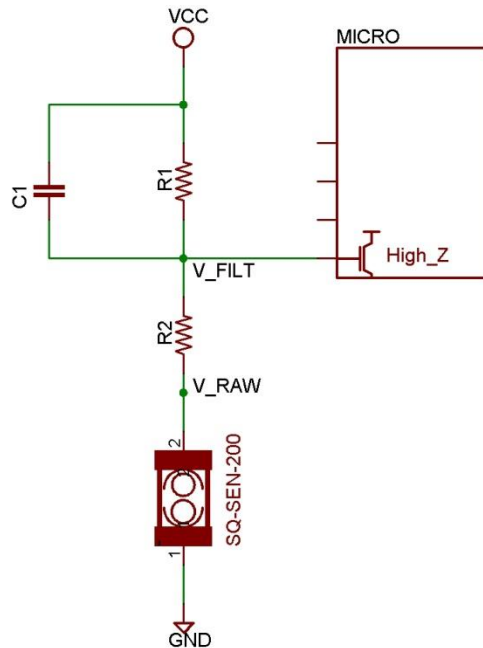

### APPLICATION NOTE

### APPLICATION CIRCUITS

#### SIMPLE CIRCUIT

- Best choice if minimum component count and minimum space is required.
- Do not connect a capacitor from any supply directly to the sensor. A large inrush current will occur when the sensing mechanism opens and closes, potentially damaging the sensor's contacts and reducing life of the device.
- Note:** It is recommended to use a 10x probe for circuit debugging. If a 1x probe is used, the series resistance will cause a large voltage droop.

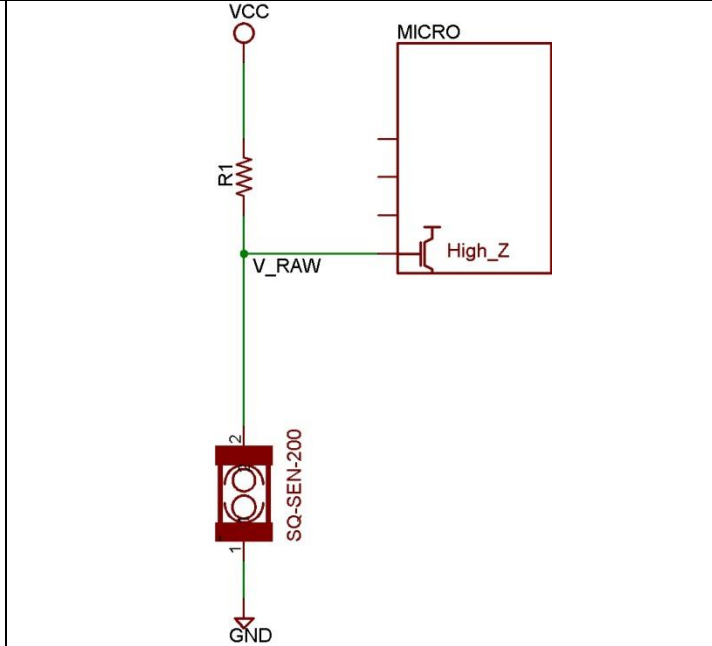

#### AC COUPLING CIRCUIT

- Best choice if the output signal needs to be guaranteed low (not high or low) when at rest.
- R1 and R2 form a voltage divider so for ample voltage swings at V\_OUT, R1 should be  $> 5R2$
- C1 and C2 form a capacitive voltage divider, so for ample voltage swings, C1 should be  $> 5C2$ .
- R2 should limit the current the current from the capacitor through the switch to  $< 1$  mA.
- R3 drains the gate charge from the high impedance input on the digital system.
- See the Flexible Filter Circuit above for some example values or consult SignalQuest application support for further information.
- Note:** It is recommended to use a 10x probe for circuit debugging. If a 1x probe is used, the series resistance will cause a large voltage droop.

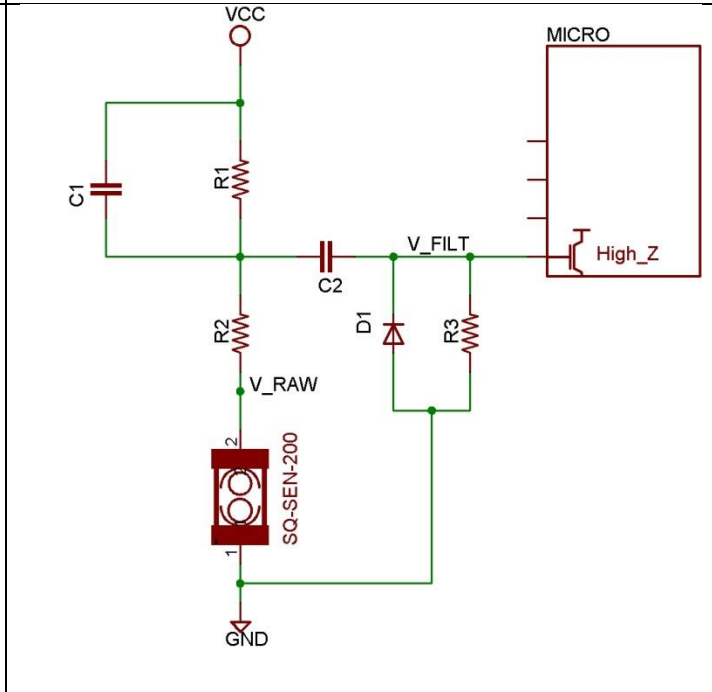

### APPLICATION NOTE

### APPLICATION CIRCUITS

#### BAD CIRCUIT

- Do not connect a capacitor from any supply directly to the sensor. A large inrush current will occur when the sensing mechanism opens and closes, potentially damaging the sensor's contacts and reducing life of the device.
- Note:** It is recommended to use a 10x probe for circuit debugging. If a 1x probe is used, the series resistance will cause a large voltage droop.

