

## GT-HE910-G



## Product description

Rev. 9 – 17/03/2013

**Contents**

1. Overview..... 3

2. Hardware Interface Description..... 3

    2.1 Main features of the GT-HE910-G ..... 3

    2.2 Hardware block diagram..... 4

3. Interface description ..... 5

    3.1 Molex 4 pin connector – Power connector ..... 5

        3.1.1 Power Supply ..... 5

        3.1.2 Supply voltage requirements ..... 6

    3.2 USB CONNECTOR..... 6

    3.3 SMA CONNECTOR..... 6

    3.4 SIM DRAWER ..... 6

    3.5 RS-232 Interface ..... 7

    3.6 AUX Interface ..... 8

    3.7 Status LED ..... 9

        3.7.1 Red LED ..... 9

        3.7.2 Green LED..... 9

4. OPTION: Watchdog operation ..... 10

5. Mechanical Characteristics ..... 11

    5.1 General mechanical description..... 11

    5.2 Environmental requirements ..... 11

    5.3 Protection class ..... 11

    5.4 RoHS compliance ..... 11

6. SAFETY RECOMMANDATIONS..... 12

7. Two Years Limited Warranty..... 12

8. Certifications ..... 13

## 1. Overview

The GT-HE910-G is a complete Cellular Terminal solution for GSM/UMTS GPS applications. Based on Telit HE910-DG module.

## 2. Hardware Interface Description

### 2.1 Main features of the GT-HE910-G

| Feature                               | Implementation   |
|---------------------------------------|--|
| Incorporates Telit HE910-DG module    | The Telit module handles all GSM/UMTS GPS processing with PYTHON script  |
| OPTION:<br>PIC16F1824 Microcontroller | For Modem ON/OFF and Watchdog  |
| Frequency bands                       | GSM: 850/900/1800/1900MHz<br>UMTS/HSPA+: 800/850/900/1700/1900/2100MHz   |
| Power supply                          | Single supply voltage 6V DC to 55V DC<br>connector 4 pin micro-fit 3mm   |
| ADC and GPIO inputs                   | Two outputs optocouplers open collector drive 100ma<br>Two inputs optocouplers, 0-55v<br>One ADC 10 bit , 0-55V<br>connector 6 pin micro-fit 3mm |
| Communication                         | Modem Full RS232, connector D-Type 9pin (DB-9)<br>Modem USB, <b>Connector USB Type B High retention</b>  |
| Antennas                              | GSM/UMTS GPS via SMA connectors  |

## 2.2 Hardware block diagram

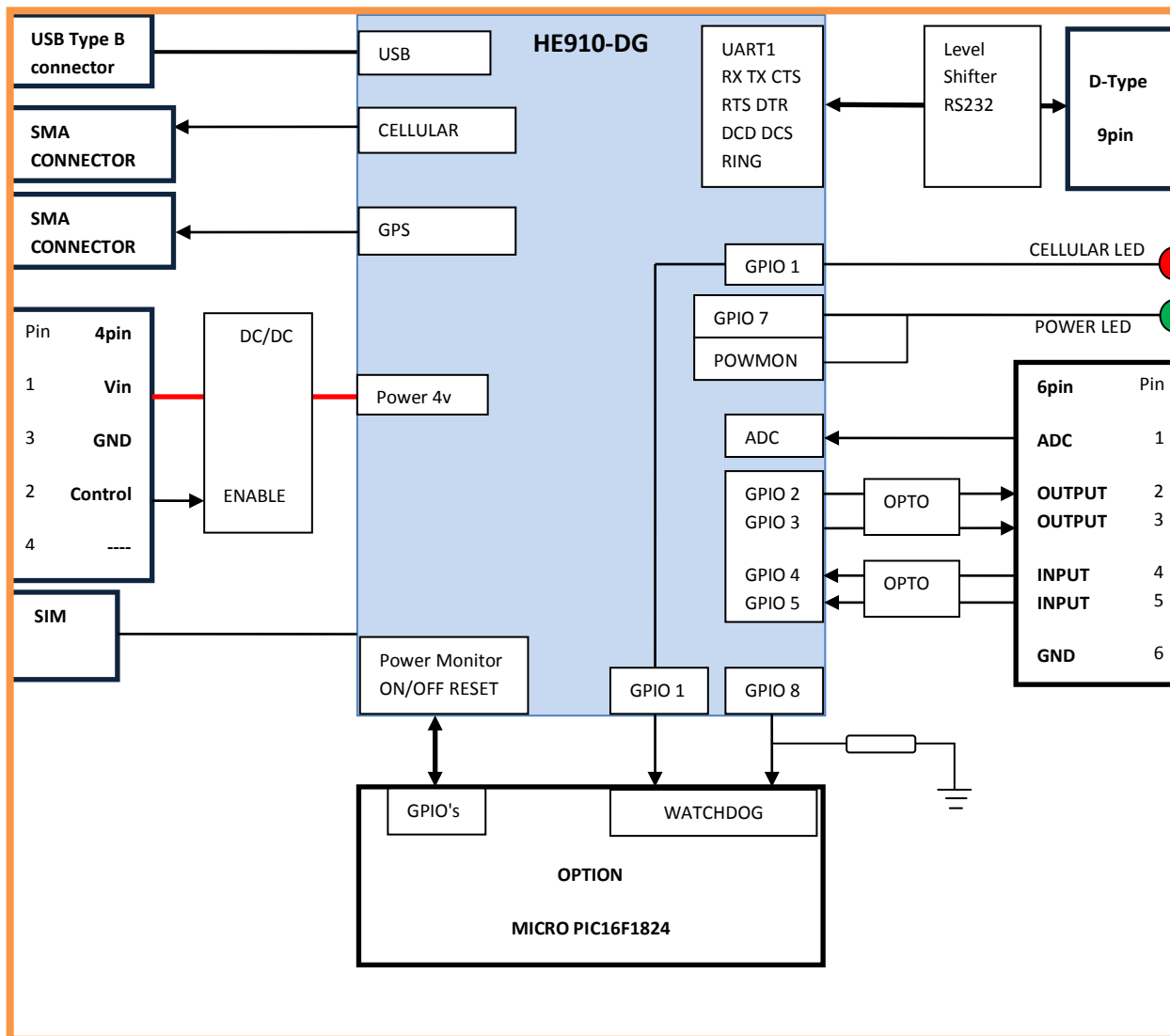

### 3. Interface description

#### 3.1 Molex 4 pin connector – Power connector

##### 3.1.1 Power Supply

The power supply of the GT-HE910-G Terminal requires a single voltage source of POWER 6V-55V capable of providing a peak during an active transmission. The GT-HE910-G Terminal is protected against supply voltage reversal. An internal fuse 1.1A 60V ensures an electrical safety according to EN60950-1. This fuse is not removable. A fast blow fuse of 0.8A is necessary for 24V power supply system (for vehicles).

The power supply recommended being any safety approved power supply certified IEC 60950-1 or EN 60950-1 or UL 60950-1 with limited output current up to 2A. The type of the receptacle assembled on the GT-HE910-G Terminal is 4 pin Micro Mate-N-LOK 3mm (0.11 inch) from MOLEX.

| Pin | Signal name  | Use  |
|-----|--------------|--|
| 1   | POWER        | Input Power supply range 6-55V   |
| 2   | Power Enable | Control pin to turn ON/OFF Terminal power.<br>When putting this pin to voltage >6V the unit will be turn OFF.<br>When putting this pin OPEN or GND the unit will be turn ON. |
| 3   | GND          | Ground   |
| 4   |              | Not connected  |

Pin assignment of the power plug including power supply and Power Enable

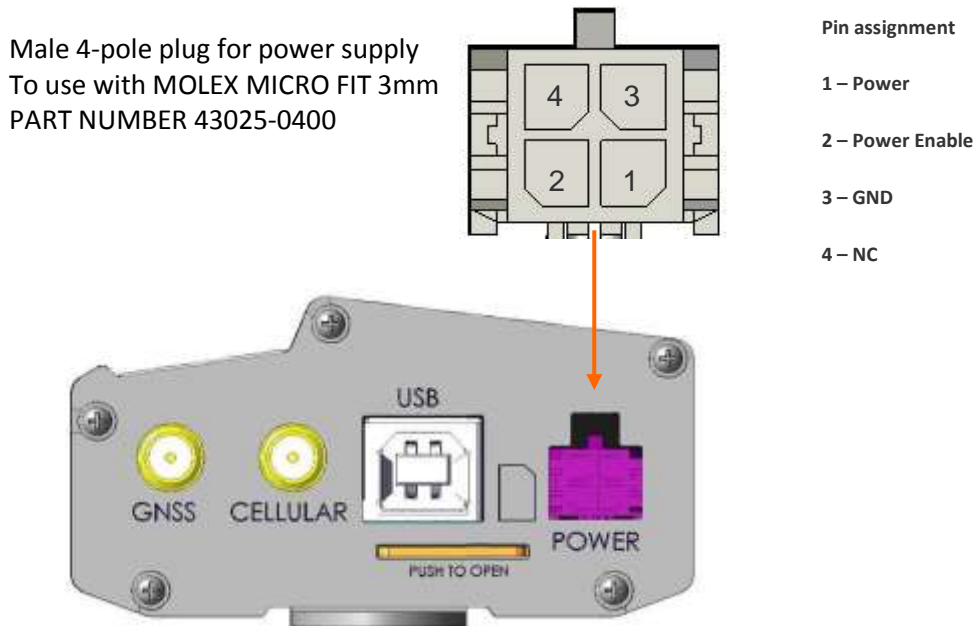

### 3.1.2 Supply voltage requirements

The DC power supply must be connected to the POWER input:

- Input voltage range 6 - 55V DC
- Nominal Voltage 12V DC
- Power Supply current rating: max. 2A @12V
- Power Supply ripple: max. 120mV
- Input current in idle mode: 20mA @ 12V
- Input average current in communication mode: 100mA @ 12V

### 3.2 USB CONNECTOR

The USB CONNECTOR of the GT-HE910-G Terminal is **USB TYPE B**, This USB TYPE B CONNECTOR on the GT-HE910-G is a **High retention** connector. It will need 15 Newton to disconnect the USB CONNECTOR.

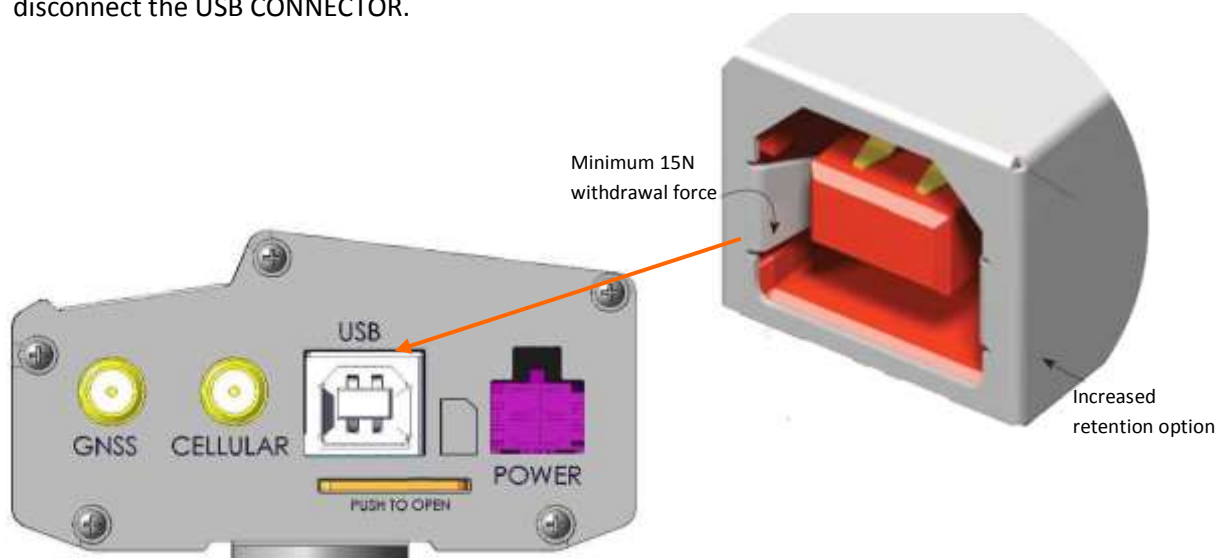

### 3.3 SMA CONNECTOR

The GT-HE910-G Terminal uses SMA CONNECTORS for ANTENNAS.  
For CELLULAR ANTENNA use the 5 band ANTENNA with 2.5dB gain.  
For GPS ANTENNA use the ACTIVE GPS ANTENNA with 25-28dB gain.

### 3.4 SIM DRAWER

Please insert the SIM card on the following direction into the SIM push-push.

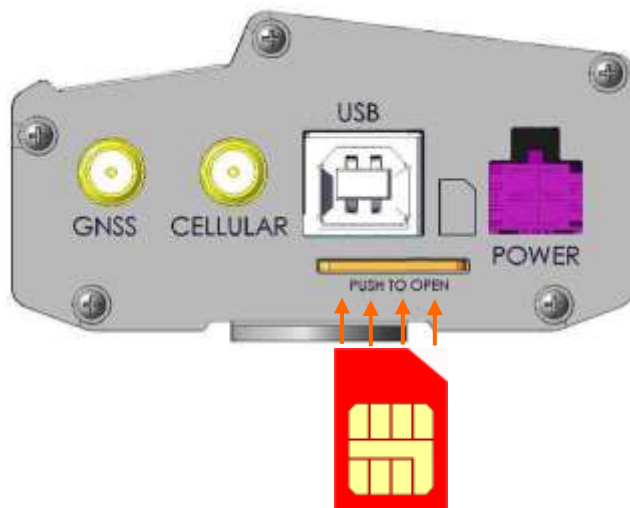

### 3.5 RS-232 Interface

The serial interface of the GT-HE910-G is intended for the communication between the GSM/UMTS GPS module and the host application. This RS-232 interface is a data and control interface for transmitting data. It accepts, AT commands and provides multiplexed channels. EMC immunity complies with the vehicular environment requirements according to EN 301 489-7.

The user interface of the GT-HE910-G is accessible from a Data Terminal Equipment DTE connected to the RS232 interface and it is managed by AT commands according to the GSM/UMTS GPS specification. The supported commands are listed in the AT Commands Reference Guide.

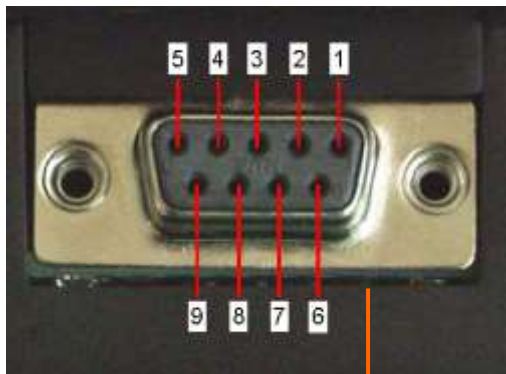

Pin assignment RS-232

| Pin no. | Signal name | I/O | Function of application |
|---------|-------------|-----|-------------------------|
| 1       | DCD         | O   | Data Carrier Detected   |
| 2       | RXD         | O   | Receive Data            |
| 3       | TXD         | I   | Transmit Data           |
| 4       | DTR         | I   | Data Terminal Ready     |
| 5       | GND         | -   | Ground                  |
| 6       | DSR         | O   | Data Set Ready          |
| 7       | RTS         | I   | Request To Send         |
| 8       | CTS         | O   | Clear To Send           |
| 9       | RING        | O   | Ring Indication         |

D-Type 9 pin female RS232



Connector type on the terminal is:

- RS-232 through D-Type 9-pin female
- Baud rate from 300 to 230,400 bit/s
- Short circuit (to Ground) protection on all outputs.
- Input voltage range: -12V to +12V

### 3.6 AUX Interface

The AUX interface provides via Male 6-pole plug connector, the following options:

- 2 digital inputs optocouplers, input 0-55vdc.
- 2 outputs optocouplers, drive up to 100ma, external diode needed when driving a relay.
- 1 ADC (10 bit) input 0-55v.
- 1 Ground pin.

#### Pin assignment

1. ADC
2. GPIO 2 -- OUTPUT
3. GPIO 3 -- OUTPUT
4. GPIO 4 -- INPUT
5. GPIO 5 -- INPUT
6. GND



Male 6-pole plug.  
To use with MOLEX MICRO FIT  
PART NUMBER 43025-0600.

| Pin # | Color  |
|-------|--------|
| 1     | Red    |
| 2     | White  |
| 3     | Green  |
| 4     | Blue   |
| 5     | Yellow |
| 6     | Black  |

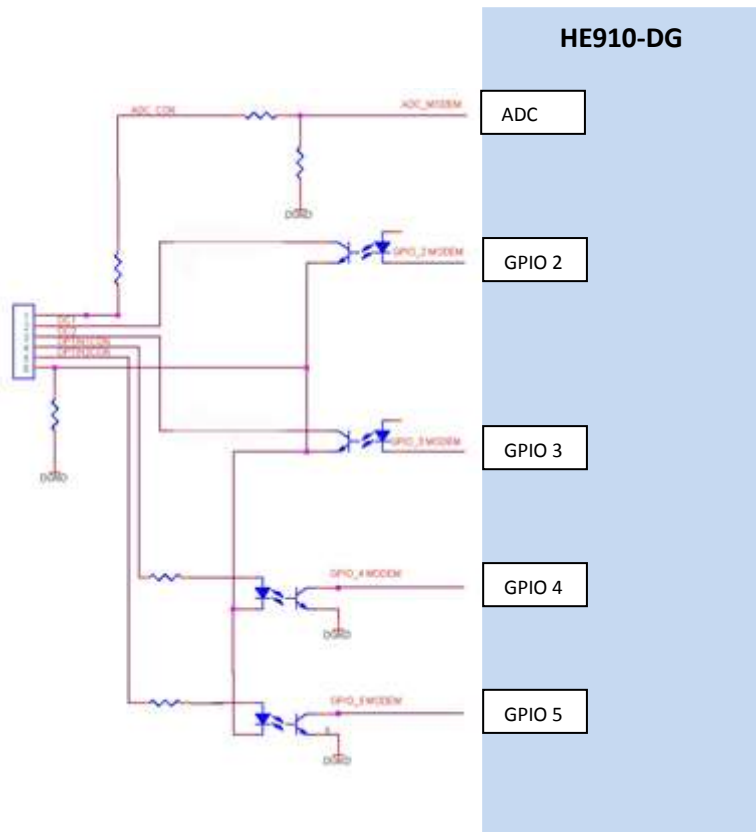



## 3.7 Status LED

### 3.7.1 Red LED

The Red LED is connected to GPIO1, OFF by default.

| Red LED status                                | Device Status               |
|---|-----------------------------|
| permanently on                                | a call is active            |
| fast interrupt sequence (period 0,5s, Ton 1s) | Net search / Not registered |
| slow interrupt sequence (period 0,3s, Ton 3s) | Registered full service     |
| permanently off                               | device off                  |

The LED can use for Network status or controlled by the user.

To activate GSM status Red LED "AT#GPIO=1,0,2;#SLED=2,1,1"

Red LED ON: "AT#GPIO=1,1,1"

Red LED OFF: "AT#GPIO=1,0,1"

### 3.7.2 Green LED

The Green LED is connected to GPIO7, ON by default (at power up).

| Green LED status | Device Status |
|------------------|---------------|
| permanently ON   | Device active |
| permanently OFF  | device off    |

Green LED control:

Green LED ON: "AT#GPIO=7,1,1" (Default)

Green LED OFF: "AT#GPIO=7,0,1"

## 4. OPTION: Watchdog operation

The GT-HE910-G has internal Watchdog option. **If the modem was turns OFF**, the watchdog will start the modem each 30 min.

### PYTHON script Watchdog:

1. New terminal will be shipped with the Watchdog disable. Watchdog starts working, only when the Modem's GPIO8 changes first time to HIGH and then LOW. Each time terminal will turn OFF and ON, Watchdog will be disable.
2. Standard operation of the PYTHON script, each 2min the PYTHON script will change GPIO8 HIGH for 1 second or more and then back to LOW.
3. If the PYTHON script is not changing the GPIO8 every 2min, the Watchdog will restart the internal power supply, which will reboot the terminal.
4. To start the Watchdog operation: **"AT#GPIO=8,0,1;#GPIO=8,1,1"**

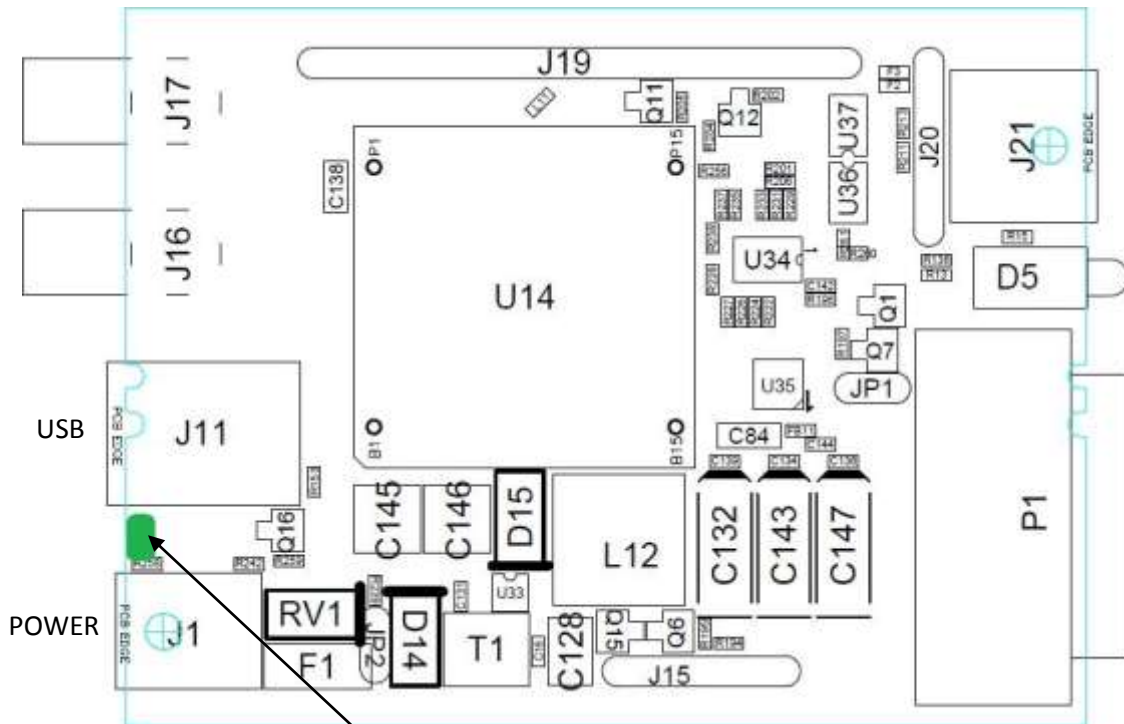

Green Led for Watchdog indication Led blinking for 2 seconds each time Watchdog command will appear

## 5. Mechanical Characteristics

### 5.1 General mechanical description

|                            |  |
|----------------------------|--|
| Weight                     | 180g (6.35oz)<br>0.4 lb                              |
| Dimensions (max) L x W x H | 83mm x 64mm x 34mm<br>3.26inch x 2.51inch x 1.33inch |
| Case material              | Aluminum   |

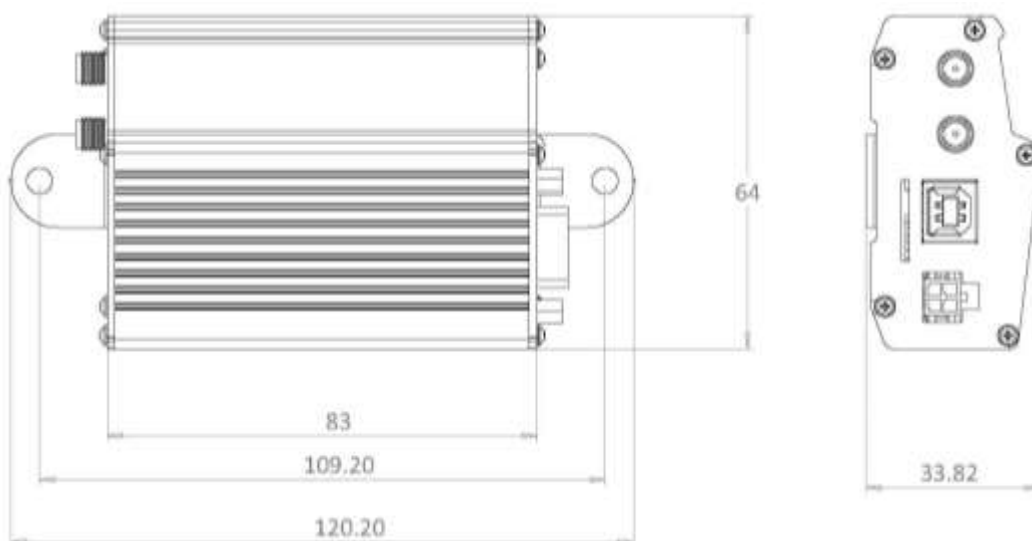

### 5.2 Environmental requirements

|                             |  |  |
|-----------------------------|--|--|
| Operating temperature range | -20°C to +55°C<br>-4°F to 131°F<br>ambient temperature | The module is fully functional (*) in all the temperature range and it fully meets the ETSI specifications.  |
|                             | -30°C to +70°C<br>-22°F to 158°F                       | The module is fully functional (*) in all the temperature range. Temperatures outside of the range -20°C to +55°C (-4°F to 131°F) might slightly deviate from ETSI specifications. |
| Humidity                    | 5% - 85%   |  |

(\*)Functional: the module is able to make and receive data calls and SMS.

### 5.3 Protection class

IP40 Avoid exposing the Terminal to liquid or moisture.

### 5.4 RoHS compliance

All hardware components are fully compliant with the EU RoHS and WEEE Directives.

## 6. SAFETY RECOMMENDATIONS

### READ CAREFULLY

1. The unit does not provide protection from lightning and surge. For outdoor installation use outdoor nonmetallic case safety approved according UL 50. Additionally you should provide protection from lightning and over voltage according National code.

2. Be sure the use of this product is allowed in the country and in the environment required. The use of this product may be dangerous and has to be avoided in the following areas: Where it can interfere with other electronic devices in environments such as hospitals, airports, aircrafts, etc. Where there is risk of explosion such as gasoline stations, oil refineries, etc. It is responsibility of the user to enforce the country regulation and the specific environment regulation. Do not disassemble the product; any mark of tampering will compromise the warranty validity. We recommend following the instructions of the hardware user guides for a correct wiring of the product. The product has to be supplied with a stabilized voltage source and the wiring has to be conforming to the security and fire prevention regulations. The product has to be handled with care, avoiding any contact with the pins because electrostatic discharges may damage the product itself. Same cautions have to be taken for the SIM, checking carefully the instruction for its use. Do not insert or remove the SIM when the product is in power saving mode. The system integrator is responsible of the functioning of the final product; therefore, care has to be given to the external components of the unit, as well as of any project or installation issue, because the risk of disturbing the GSM network or external devices or having impact on the security. Should there be any doubt, please refer to the technical documentation and the regulations in force. Every unit has to be equipped with a proper antenna with specific characteristics. The antenna has to be installed with care in order to avoid any interference with other electronic devices and has to guarantee a minimum distance from the body (20 cm/8"). In case this requirement cannot be satisfied, the system integrator should assess the final product against the SAR regulation. The European Community provides some Directives for the electronic equipment introduced on the market. All the relevant information available on the European Community website:

<http://europa.eu.int/comm/enterprise/rtte/dir99-5.htm> The text of the Directive 99/05 regarding telecommunication equipment is available, while the applicable Directives (Low Voltage and EMC) are available at:

[http://europa.eu.int/comm/enterprise/electr\\_equipment/index\\_en.htm](http://europa.eu.int/comm/enterprise/electr_equipment/index_en.htm)

## 7. Two Years Limited Warranty

GateTel warrants, to the original purchaser, that this equipment shall be free of defects in materials and workmanship for a period of two (2) years from purchase date.

This warranty does not apply if the product has been misused or has been damaged by accident, abuse, misuse, or misapplication or if it has been modified without written permission.

## 8. Certifications

Name: Industrial GSM/UMTS GPS Communication unit

Model: GT-HE910-G

Reference standard(s):

Radio

| Number | Market | Standard          | Procedure                  |
|--------|--------|-------------------|----------------------------|
| 1      | Europe | EN 301 511 V9.0.2 | Spurious Emissions testing |

EMC

| Number | Market | Standard               | Procedure                  |
|--------|--------|------------------------|----------------------------|
| 2      | Europe | EN 301 489-7 V1.2.1    | partial testing and report |
| 3      | USA    | 47 CFR part 15:06 sb.B | Verification               |

Safety

| Number | Market | Standard      | Procedure |
|--------|--------|---------------|-----------|
| 4      | Europe | EN 60950-1:06 | DoC       |